



This manual has been updated, yet due to Keeway's improvements you may find some difference between your motorcycle and this manual, therefore if you have any questions or comments please contact local Keeway Service Center

For any repairs not mentioned in this manual or accessories required please contact local Keeway Service Center

Use only spare parts and accessories by Keeway.



The meaning of some signs in the manual as follows:

▲ WARNING

Indicates potential hazard that could result in death and injury.

▲ CAUTION

Indicates potential hazard that could result in vehicle damage.

▲ ADVICE

Indicates special information to make maintenance easier or instructions clear.

Keeway Motor Europe

2000 Szentendre, Kozuzo u.8

Hungary

Tel: +36 26 500005

Fax: +36 26 312034

Email: info@keewaymotor.com

For more information

Visit our web page:

www.keewaymotor.com



Drive safely	3	Checking your motorcycle	16
Know your motorcycle	4	Daily check	16
Tools and indicators location	5	Regular check	16
Indicators description	6	Brakes	17
Main commands	7	Engine oil	18
Main switch	8	Rear shock absorber	19
Handle bar lock	8	Spark Plug	19
Access to compartments	9	Air filter	20
Seat	9	Battery	20
Lock for helmet hook	9	Fuse	21
Fuel tank	10	Carburetor	21
Fuel pump	10	Transmission chain	21
How to start engine	11	Rinse	22
Use kick starter engine	12	Storage	22
How to ride	12	After inactivity	22
Changing gear	13	Checks and Maintenance	23
Speed adjustment	13	Technical data	24
Brake system	14	Specifications	25
Parking	14		
Running	15		
Identify your motorcycle	15		

This manual should be considered as a formal part of your motorcycle and should always stay with it even at resale.

This chapter shows some rules you should follow through driving:

- It is necessary to consider all the requirements provided by law (license, plates, etc.)
- It is recommended that while riding confident with your motorcycle driving through low transit areas
- Never lend your motorcycle to learner, most of the accidents occur due to the lack of experience of driver
- Do not drive under the use of alcohol, drugs or medical treatment than can cause drowsiness

- Respect norms of transit and signs
- Make sure to wear helmet, gloves and protective clothing
- Drive with both hands and keep feet on the stirrup.
- Drive should not get distracted (by smoking, drinking, reading, eating, etc.)
- Check vehicle periodically (oil, fuel, etc.)
- The motorcycle is designed for two passengers. (Rider+one person)

LUGGAGE

- Performance and steadiness of loading are different from not loading
- Luggage must be fixed with rubber strip or rope.



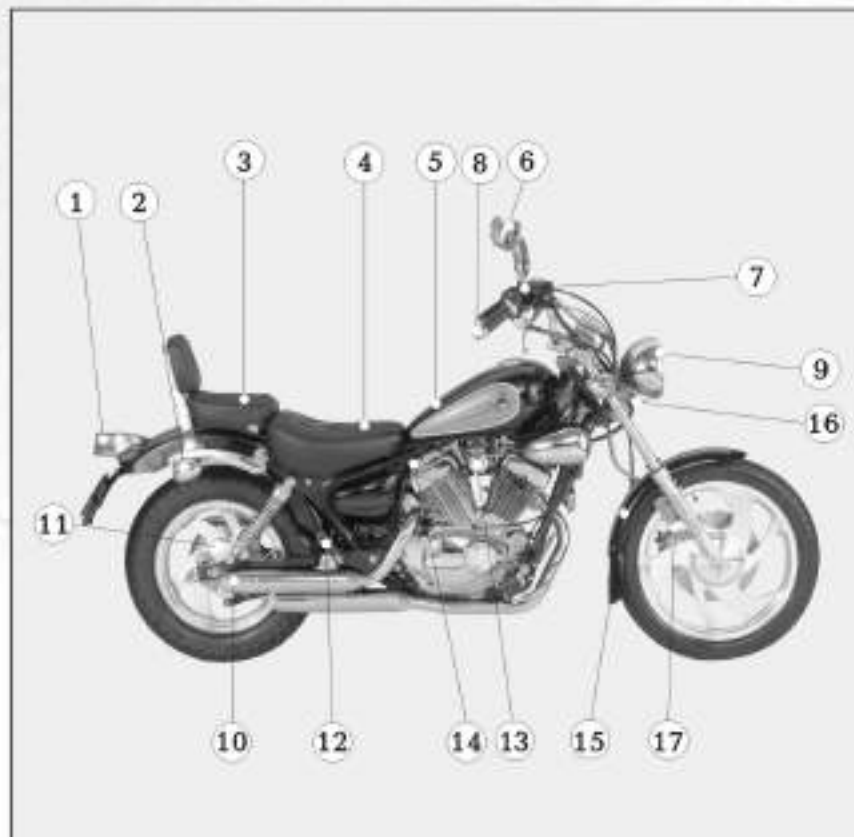

- 1) Rear Light
- 2) Rear Indicator
- 3) Passenger seat
- 4) Seat
- 5) Fuel Tank
- 6) Rear View Mirror
- 7) Brake Oil Tank
- 8) Speed Controller
- 9) Head Light
- 10) Exhaust Pipe
- 11) Drum Brake
- 12) Passenger Stirrup
- 13) Starting Motor
- 14) Kick Lever
- 15) Rear Brake pedal
- 16) Horn
- 17) Disc Brake

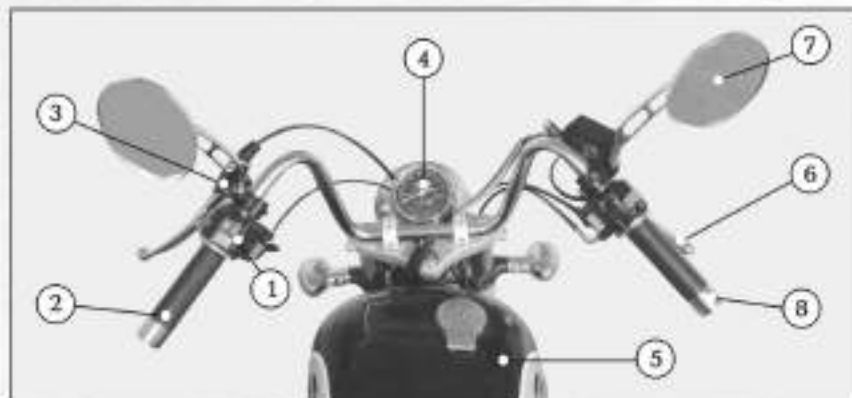

- 1) Electric commands on left handle
- 2) Clutch Controller
- 3) Rearview left mirror
- 4) Instrument Panel
- 5) Fuel indicator
- 6) Front hand brake
- 7) Rearview right mirror
- 8) Speed Controller.

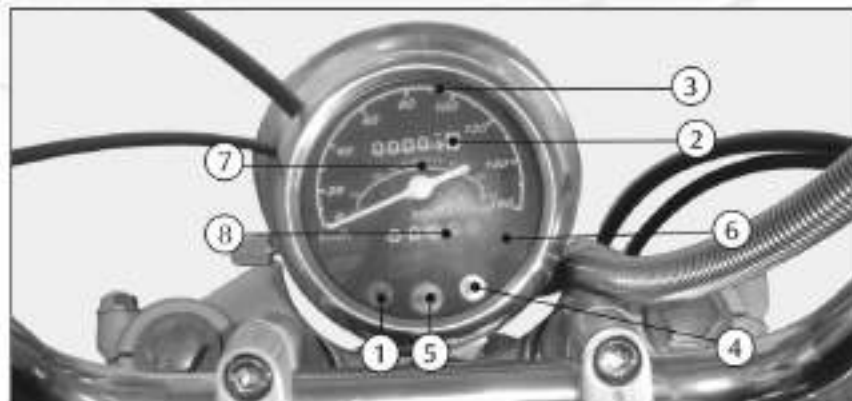

- 1) Neutral indicator
- 2) Odometer
- 3) Speedometer
- 4) Farsighted indicator
- 5) Turning Indicator
- 6) Alarm indicator.
- 7) Tachometer
- 8) Trip Meter

Left turning indicator	Flashes when left turning signal is ON
Odometer	Indicates the distance covered in kilometers (totally)
Speedometer	Speed is indicated with kilometers / hr
Right turning indicator	Flashes when right turning signal is ON
Farsighted indicator	Lights up when farsighted light is on position
Neutral indicator	Flashes when neutral is ON
Alarm indicator	Flashes when alarm is active.

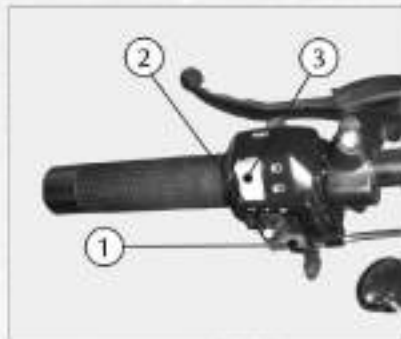

LEFT HANDLE

- 1) Horn switch
 - Pressing the switch, horn will sound.
- 2) Left Turn Indicator Switch
 - Press and hold the turn indicator switch during turn, release the switch after turn.
- 3) Changing light switch
 - ☐ Distant light- Switch to, light of head light goes upward
 - ☐ Near light- Switch to, light of head light goes downward.

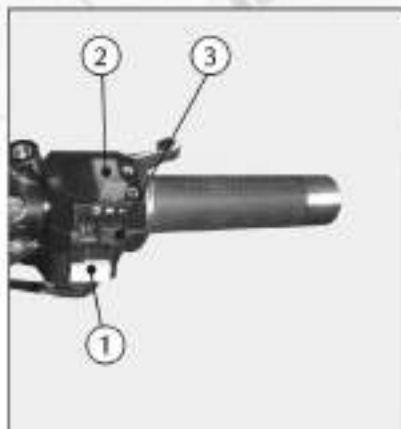

RIGHT HANDLE

- 1) Electrical starter switch
 - Press electrical starter switch, limit time of pressing electrical switch is 5 seconds, if engine does not turn on try again within a gap of 30 seconds
- 2) Head Light ON/OFF Switch
 - Pressing the switch up, head light will on and pressing the switch down head light will OFF.
- 3) Right Turn Indicator Switch
 - Press and hold the turn indicator switch during turn, release the switch after turn.

HAZARD FUNCTION

By pressing the both(LH&RH) indicator switch at a time all indicator will ON, and release the switch to OFF the hazard function.

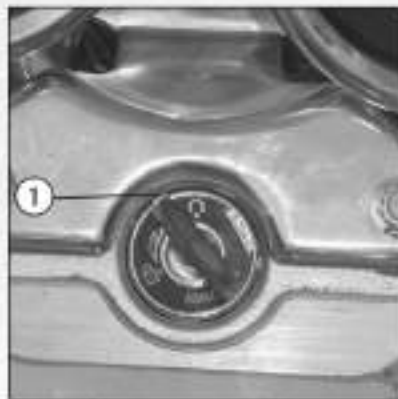

Rotation of key is used to control opening and closing of the circuitry.

Warning:
Don't use key during driving

Advise:
If the engine is not working, please close the main switch, unless which can cause battery drain or damage.

1. ON (opening)

Engine can be started
Switch lights on work normally
Horns works

Keys can't be dropped out

2. OFF (closing)

Engine is stopped
Lights can't be used
Horn not working
Engine won't start

Keys can be dropped out

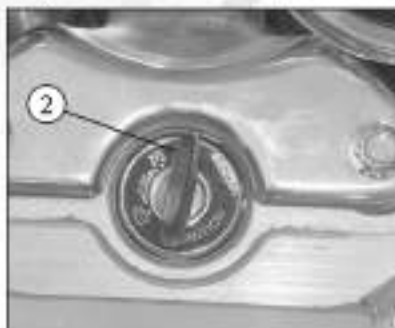

HANDLE BAR LOCK

LOCK

Do not forget to lock your handle bar when parking

1. Turn handle bar left until limit position

2. Insert key and turn clockwise

3. Take out the key.

Warning:
Do not push your bike while this procedure or it will fall down

Try to turn the handle bar to make sure it is locked.

How to open handle bar lock.

1. Introduce key and to OFF position.



HOW TO WITHDRAW CUSHION SEAT

1. Remove screws from bottom of seat, one from each side
2. Bring up bottom of seat, lower the seat, push firmly and lay screws.

Warning:
Do not forget to tighten screws.



LOCK FOR HELMET HOOK

1. Insert key and turn clockwise
2. Open the hook lock
3. Hang the helmet and lock.

Attention:

Can not drive bike with helmet hung.
This will be dragged inside and will affect safe driving.



Keeway Motor Europe

2000 Szentendre, Kozuzo u.8

Hungary

Tel: +36 26 500005

Fax: +36 26 312034

Email: info@keewaymotor.com

For more information

Visit our web page:

www.keewaymotor.com



FUEL TANK

1. Push the key in buckle and turn to right to open the outer cover of fuel tank
2. Turn cap, fuel tank to left and drop it out
3. Add unleaded fuel to it
4. Take cap, fuel tank back and tight it, and then close the outer cover of fuel tank.

TANK CAPACITY
8 lts.

Warning:

- Fuel is combustible material and can cause fire under some conditions.
- When loading fuel, should be in ventilated areas and with engine OFF
- Avoid skin contact, inhaling or ingestion with fuel.

FUEL PUMP

Close position (o)

1. When it appears in this position fuel does not get through carburetor
2. That is the right position when bike is not being utilized.



Open position (I)

1. When it stays at this position fuel get through carburetor
2. This is the right position when bike is being utilized.



BEFORE STARTING THE ENGINE

- With side stand.
- Keep the motorcycle on main stand
- Driver must stand on the left of the vehicle.

Don't start engine in airless or airtight room for waste was including poisonous elements which can cause death.

WHEN STARTING THE ENGINE

1. Turn fuel pump switch to open position



2. Verify the ON/OFF push button remains ON



3. Turn the switch to ON position



4. When engine is cold set choke into position 1



5. When engine is preheated set choke into position 2

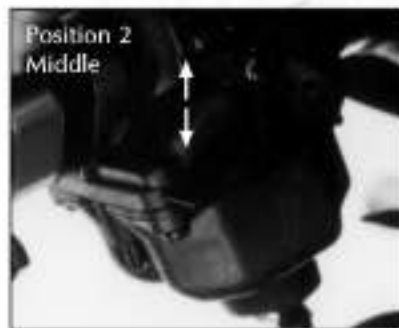

6. Hold steering handle and then press electrical switch.



7. Don't make any rushing out with cold engine, it is recommended to warm it out, driving at a limited speed during the first kilometers of the ride.

USE KICK STARTER ENGINE

1. Follow steps 1-5 from chapter "When starting the engine"
2. Step on the kick lever for applying the force.



- Advice:**
Turn the kick starter lever back after starting engine.

HOW TO RIDE

1. Turn main support back. Nip the rear brake with left hand and grasp support handle with right hand, and then push the vehicle forward so as to turn main support back.

Advice:

In order to turn main support back, don't grasp seat.

2. Stride the vehicle. Hold the handle bar with both hands, stride the vehicle from left side. Sit straightly and your left foot can't be of the ground

3. If driving with passenger open back stirrup, if not keep them closed.

Caution:

To avoid abrupt way out adjust connection between accelerator/clutch.

Don't increase the engine speed without any reason before riding.

CHANGING GEAR

This motorcycle have 5 gears which can manipulated through clutch and gear lever.



This is the diagram of how gears are located.

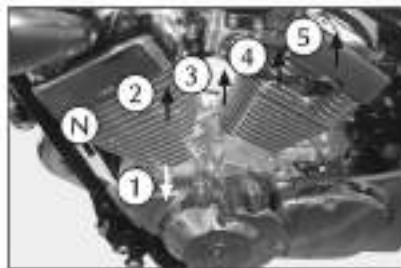

Diagram shown below indicates when is recommended to change gear in accordance to kilometers ridden.

KMS.	1 st g.	2 nd g.	3 rd g.	4 th g.	5 th g.
0-300	10	24	30	35	40
300-600	15	30	35	40	45
600-1000	15	30	40	45	50
1000-1500	15	35	45	50	60

SPEED ADJUSTMENT

Use steering handle to adjust speed

1. To the driver:
Speed is more and more faster to the driver
2. Against the driver:
Speed is more and more slower against the driver.



BRAKE SYSTEM

- Please loosen steering bar in advance, and then hold front and rear brake bar tightly.
- Hold front and rear brake gradually is the proper way to operate.
- If needed to brake during up hill, use both hands, don't try to maintain by speeding or damage will be caused.

Warning:

You should brake early in dump ground snowy ground or frozen ground where more time is needed than in dry ground

Don't brake constantly during long downhill or damage will be caused. Check Brake oil level constantly.

PARKING

- Don't lean your motorcycle on walls
- Stand your motorcycle on steady floor
- Don't leave your motorcycle without surveillance, nor with engine ON, nor with key on
- Don't sit on your motorcycle while leaning on main support
- Avoid touching any components that may be hot.

Keeway Motor Europe

2000 Szentendre, Kozuzo u.8
Hungary

Tel: +36 26 500005

Fax: +36 26 312034

Email: info@keewaymotor.com

For more information

Visit our web page:

www.keewaymotor.com



RUNNING

The motorcycle running is fundamental to long lasting warranty and right operation of your motorcycle

0 - 100 Kms.

For the first 100 km. Operform with caution on the brakes and avoid using your brakes rushing out and at prolonged time.

This will permit optimum operation

0 - 500 Kms.

For the first 500 km. Don't drive your motorcycle faster than 80% of the limit shown.

Don't keep constant speed during long ridings at highways

After 1000 Kms.

Speed up gradually your motorcycle until maximum performance has been reached.

IDENTIFY YOUR MOTORCYCLE

We recommend to write down motor number, frame number and grand in the space below for a better control of your motorcycle

Engine Number

Frame Number

Brand

Important:

Modification on the id. Numbers may be penalize

Modification on the id. Numbers invalidates warranty.



Engine Number



Frame Number

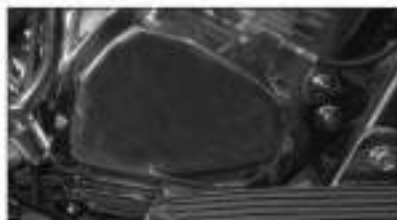

Brand

Regular check is necessary for using your motorcycle properly and preventing from accident

Daily Check

Always remember to check your motorcycle carefully before everyday riding

Regular Check

Take an overall check once half a year for better using performance

Warning:

- Breakdown or accident may happen for lacking of regular checks
- Regular check is required even if the motorcycle is lying idle
- It is of great importance to check your motorcycle after longtime of laying aside
- Check more frequently if motorcycle is being used under rainy or dusty conditions

- We recommend difficult checks to be held at local or nearest service center.

DAILY CHECK

Brake System

- Appropriate handle stroke and sensitive brake system

Tires

- No crack or damage
- No anormal abrasion
- Proper depth of tire carving.

Engine

- Enough engine oil
- Check if it run normally or any noise rising
- Check if it works well during speed accelerating and decelerating.



Here we only introduce some simple ways of checking and adjusting your motorcycle

BRAKES

- Disk brake checking

- Check from the backside of brake fixture if the disk abrasion reaches to the limits replace the two disks with new ones.



- Brake oil Replenishing

If brake oil level is lower than the limit replenish with brake oil DOT3 or

DOT4.



- Pinch rear brake handle till resistance comes up, measure if the further stroke is in the stated range

- Adjust the stroke by turning the regulating nut right to increase the travel distance and decrease it by turning left.

Caution:

- Do not use brake oil with inferior quality

- Keep brake oil away from cohering on the coating to avoid fading and chapping

Caution:

- Be sure to keep the foveae of the adjusting nut contact perfectly with the pillar surface of the pin.

Advice:

- Check the travel distance of the grip again after adjustment

- Hold the brake grip tightly to check if the prolongation of indicating line falls in the specified brake limit.



ENGINE OIL

For checking oil level

1. Remove the oil cap with oil stick
2. Tighten drew screw
3. Pour proper quantity of oil slowly into the gear box

Caution:

- Adopting of improper engine oil or oil with low quality may cause stoppage engine.
- Use main stand at a flat ground
- Remember to change engine oil periodically.
- Engine oil replacement
 1. remove drain screw of oil cap
 2. It is easier to drain the remains of the gearbox when the engine is warm
 3. Change oil filter
 4. Tighten drew screw
 5. Pour proper quantity of oil slowly into the engine.
 6. Tighten the oil plug after fulfilling.

SAE10W-40 or SAE10W-50



REAR SHOCK ABSORBER

Shock absorber springs is the vibration decrease and it can be adjusted according to load conditions.

Spring adjust

1. Lift bike by at main support
2. Turn button bracket to wanted height
3. Verify that both springs (left and right) remain at same height.

**Caution:**

- Left and right springs must be adjusted at same position, incorrect position will generate instability to handlebar control.

SPARK PLUG

- Check spark plug at 1000 kms., if dirty use a small metal brush and clean electrode
- Readjust spark plug gap between 0.6-0.8 mm.
- Readjust spark plug every 6000 kms.

Spark plug replacement

1. Disconnect cable from spark plug
2. Slacken spark plug and withdraw
3. Insert new spark plug with its gap and tighten

4. Connect cable to spark plug all the way in.

Advise:

- Do not tighten too much, just until limit
- Use spark plug NGK D7EA /CHAMPION A8YC/ NHSP/LD/D8RTC



AIR FILTER

Cleaning air filter must be done every 1000kms, according to use

If using motorcycle under dusty or wet conditions should cleaning be more frequent.

Remove the cover of the air filter.

- Removal

1. Set motorcycle over main support
2. Withdraw right bike cover pulling out
3. Remove air filter
4. Apply oil filter on the surface
5. Attach and insert cover pushing in tightly.



Caution:

- Remember to replace the wick if it is worn out
- Improper fixing of the wick may cause dust into engine, by which engine performance and usage life may be affected.

BATTERY

Check the electrolyte of the battery every 1000kms.

- Verifying your battery

1. Make sure starter switch is OFF

2. Remove left cover pulling out

3. Disconnect battery

4. Replenish the electrolyte of the battery timely except for the sealed on which needs no inspect.



Caution:

- Avoid splash fluid
- Do remember not to remove the sealing plug of the battery.

FUSE

If any electrical component is not working or is working improperly or the engine does not turn on, check your motorcycle fuse.

Fuse Checking

1. Set motorcycle over main support
2. Check fuse out of case; replace if damaged.

**Warning:**

- Do not apply fuse with improper capacity

Caution:

- Replace the electrical appliances with original brand or other specified products, by which the performance of battery will be assured
- Do not rinse the surrounding part of fuse as strongly.

Advice:

If the fuse is out of order just after replacement, go to a Vento service center immediately.

CARBURETOR

Has been adjusted for best working terms:

1. Choke
2. Rule accelerator.

**TRANSMISSION CHAIN**

While working, transmission needs lubrication and a proper adjustment, this can be provided by your Service Center.



RINSE

Regular rinse is of importance to extend the usage life of your motorcycle

1. Sweep the dirt with cloth while rinse
2. Adopt neutral detergent and wash the motorcycle with water to get rid of dirt difficult to clean
3. Dry the remaining water with clean and soft rag.

Advice:

We recommend our users to apply mixed wax and pay attention to scrub the painting and plastic parts softly to prevent spot.

Caution:

- Do remember to clean the motorcycle after engine cooled

- Keep water out of the muffler air-cleaner and electrical appliance to prevent rust

- Please rid carefully and slowly after washing your motorcycle by which brake performance may be affected.

It will return to normality after drying out.

STORAGE**Caution:**

Shield the engine and muffler with dust guard after the surface is cool.

Advice:

Please pay high attention to the following after long time of storage

1. It is of great importance to wax all parts to prevent rust.

2. To preserve the battery and reduce leakage of electricity, please take out the battery and put it at a ventilating place without exposing to light or keep it inside with negative electrode cutting off

3. Do remember to drain off all the oil of the carburetor to prevent rust.

AFTER INACTIVITY

- Rinse your motorcycle

- Check battery charge and re-charge if needed

- Check oil and fuel levels

- Use a complete check out before using.

Caution:

Test your motorcycle at moderate speed.



	Distance	KMS.			
		1000 Kms.	4000 Kms.	8000 Kms.	12000 Kms.
Fuel line			I	I	I
Fuel filter			C	C	C
Accelerator			I	I	I
Air filter			C	C	C
Spark plug			I	R	I
Valve opening			I	I	I
Engine oil		R		R every 2000 Kms.	
Filter gasket			I	I	I
Minimum speed		I			
Transmission chain			L every 1000 Kms.		
Brake pads			I	I	I
Brakes		I	I	I	I
Front brake		I	I	I	I
Liquid pressure line			R every 4 years		
Back brake		I	I	I	I
Oil pressure			R every 2 years		
Front brake light			I	I	I
Front light			I	I	I
Clutch		I	I	I	I
Basket			I	I	I
Bolt, Nut		I	I	I	I
Wheel		I	I	I	I
Steering		I	I	I	I

I: Inspection, cleaning, adjustment, lubrication and replacement if necessary C: Cleaning R: Replacement A: Adjustment L: Lubricating.



Idling Speed	1400 ± 100 rpm
Transmission system	
1st. gear	1:29.73
2nd. gear	1:18.94
3rd. gear	1:14.17
4th. gear	1:14.25
5th. gear	1:9.23
Front tire pressure	230Kpa
Rear tire pressure	230Kpa
Battery	12V-6Ah/YUASA/YTX7A-BS
Generator	Alternator
Headlight	12V-35/35W
Rear brake lamp	12V-21/5W
Maximum speed	118 km/h
Slanting capacity	20°
Distance for braking	7m
Fuel consumption	2.3 lts./100kms.

Keeway Motor Europe
2000 Szentendre, Kozuzo u.8
Hungary
Tel: +36 26 500005
Fax: +36 26 312034
Email: info@keewaymotor.com
For more information
Visit our web page:
www.keewaymotor.com



Type	Supershadow
Displacement	249cc
Cylinders	2
Cooling System	Air cooled
Bore X Stroke	49mm x 66mm
Power stipulated	14.5km/8750min ⁻¹
Max. Torque	15Nm/8000min ⁻¹
Starting System	Electric
Starter Style	CDI
Clutch Type	Wet shoe, multi plates
Gear Shift	5 speed
Length	2250mm
Width	740mm
Height	1160mm
Wheel Base	1530mm
Dead Weight	149kg
Passenger allowed	Two (Rider + one person)
Suspension	Hydraulic
Front Brake	Disc

Keeway Motor Europe

2000 Szentendre, Kozuzo u.8

Hungary

Tel: +36 26 500005

Fax: +36 26 312034

Email: info@keewaymotor.com

For more information

Visit our web page:

www.keewaymotor.com

Keeway Motor Europe
2000 Szentendre, Kozuzo u.8
Hungary
Tel: +36 26 500005
Fax: +36 26 312034
Email: info@keewaymotor.com
For more information
Visit our web page:
www.keewaymotor.com

Rear Brake	Drum
Front Tire	3.0-18
Rear Tire	130/90-15
Fuel Tank Capacity	8.0Lts
Engine Oil	1.0 L.

AUTOMATICS BY ELECTRICITY PRINCIPLE DIAGRAM

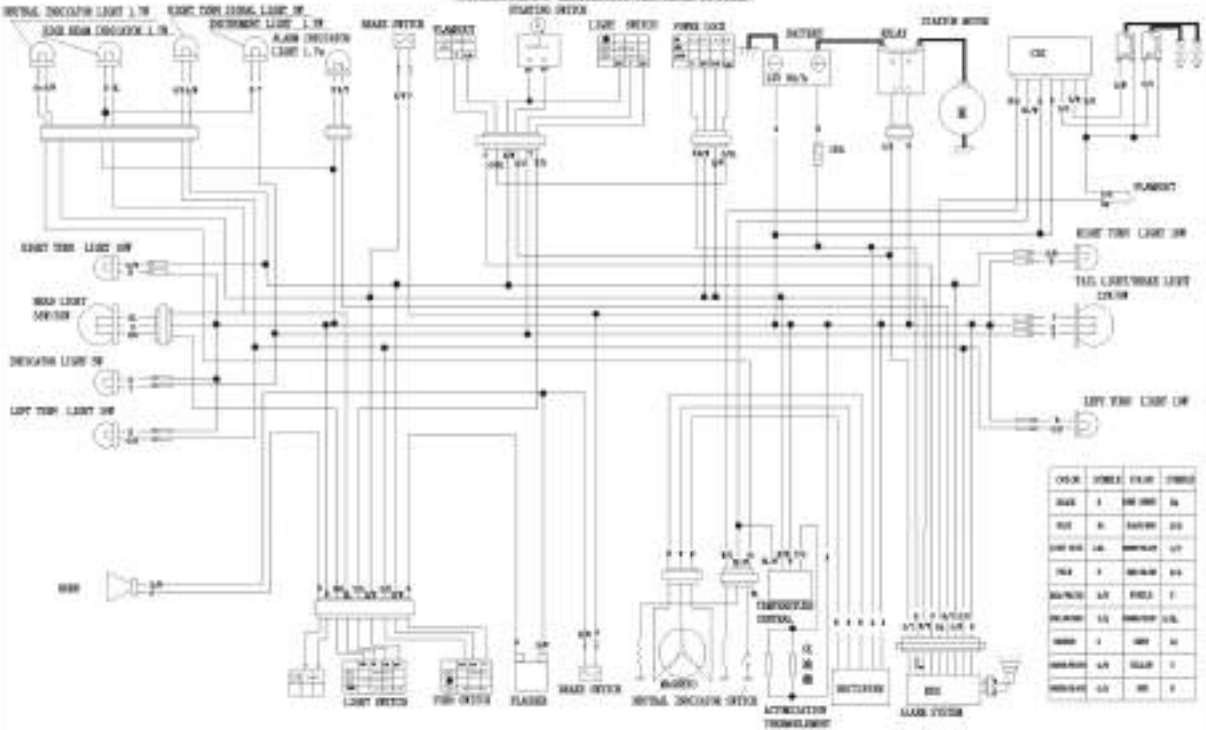

CODE	SYMBOL	DESCRIPTION	REMARKS
001	1	100 WATT	10
002	2	200 WATT	20
003	3	300 WATT	30
004	4	400 WATT	40
005	5	500 WATT	50
006	6	600 WATT	60
007	7	700 WATT	70
008	8	800 WATT	80
009	9	900 WATT	90
010	10	1000 WATT	100